

COMPACT Series

One step shrink wrap machines without tunnel

Packaging Solutions



COMPACT Series

One step shrink wrap machines without tunnel



Technical Specifications

	Compact 4500-i	Compact 5800-i	Compact 7000-i	Compact 8000-i	Compact 5800-MC
Max. Capacity: 5-10 pack / min "i Series"	Max. Packaging Sizes (WxLxH): 6 x 14 x 6"	10 x 18 x 6"	14 x 22 x 6"	18 x 26 x 6"	10 x 18 x 6"
Max. Capacity: 7-12 pack / min "MC Series"	Max. Film Width: 16"	20"	24"	28"	20"
Max. Roll Diameter: Ø12" standard	Installed Power (50-60Hz): 200-240V, 15 Ampere, 1 Phase	200-240V, 17 Ampere, 1 Phase	3x220V, 19 Ampere, 3 Phase	3x220V, 28 Ampere, 3 Phase	3x220V, 19 Ampere, 3 Phase
Working Height (E): 34" (8000-i Series 38")	Consumption (Max. / Average): 4 kW / 3 kW	5 kW / 3 kW	6 kW / 4 kW	9 kW / 5 kW	6 kW / 4 kW
Film Types: POF 0.2-1.4 mil	Chamber Sizes: 18 x 12 x 10"	23 x 17 x 10"	28 x 20 x 10"	32 x 24 x 10"	23 x 17 x 10"
PVC: 0.6-1 mil	Dimensions (AxBxCxD): 43 x 24 x 45 x 11"	48 x 29 x 45 x 11"	58 x 34 x 45 x 11"	72 x 39 x 48 x 11"	62 x 28 x 44 x 11"
Max. Product Height: 6" (Optionally Higher)	Palletized Size (WxLxH): 31 x 47 x 30"	31 x 47 x 30"	37 x 63 x 31"	39 x 76 x 48"	37 x 67 x 34"
Color: Light gray RAL7035	Weight (Net / Gross): 220 lbs / 287 lbs	265 lbs / 331 lbs	333 lbs / 452 lbs	388 lbs / 494 lbs	315 lbs / 390 lbs

* MG: Magnetic hold down series, MC: Automatic discharge series

Features:

- Seal & shrink single-step application in the same chamber
- Practical and compact solution for low capacity packaging requirements
- Easily transportable on wheels inside a facility
- Timers and temperature controls by digital control panel
- Magnetic holder keeps the chamber hood closed automatically
- Adjustable perforators for air discharge during shrinkage

Intelligent Sealing System & Advantages:

- Sealing blade power is generated as much as it is needed
- Adaptive temperature power control during variable cycle times
- Start-up power for the sealing blade is controlled with intelligent system.
- Increased duration of composite blade-supports due to efficient heat control
- Sustainable sealing quality and process accuracy by stabilized heat control

Sealing:

- Mechanical switch triggers heating of wire and chamber when the hood is closed
- Sealing is actuated in between wire and silicon rubber by manually closed hood
- Teflon belt covered silicon rubber increase sealing quality and life-span of silicon
- Sealing wire is embedded into heat-resistant composite fiber
- Solid state relays in electrical cabinet helps operating long-term and quietly

Flexibility:

- Height adjustable package mesh tray for center sealing option
- Adjustable power of sealing blade against different film thickness
- Poly-bagging option (without shrink) by switching off the fan
- Temperature, timer other options are controlled with digital system
- Various language options are available in digital control panel
- Service menu is available in digital control panel
- Film roll holder with easy to slide, load and align each package

Quality:

- Working option without pressured air need
- ISO9001 quality standards with the relevant norm's confirmation
- CE certifications, complies with the latest CE directives
- World-wide approved brands for all mechanical and electrical components
- 1 year warranty for nonwearable parts against manufacturing faults
- 5 years spare part availability

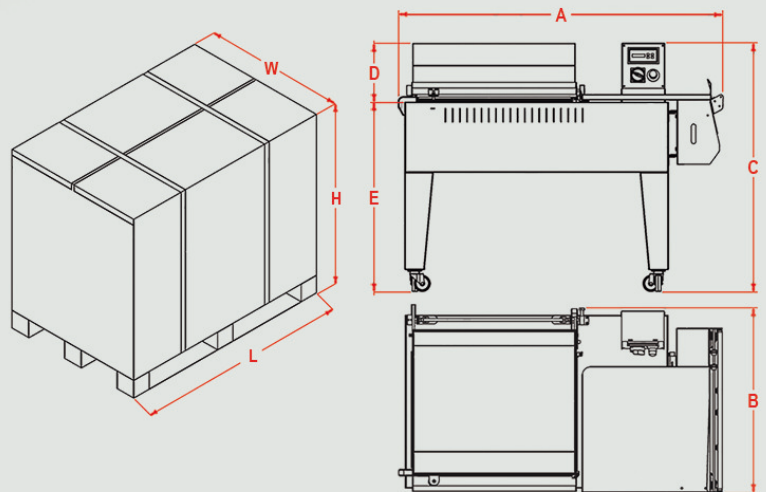

R5 EN